

**FEMALE BRANCH TEE (STUD END TAPER THREAD)
METRIC OD TUBES X NPT THREAD-N**

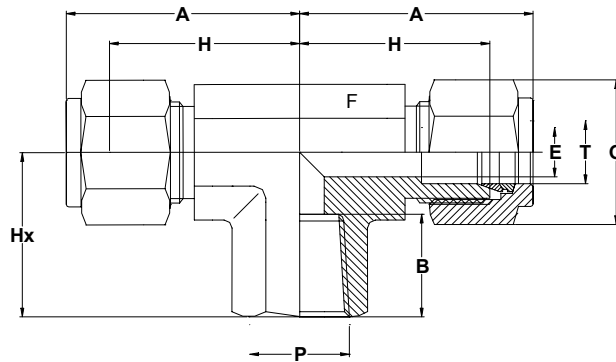

									PART NO.
	NPT (F)	mm	mm	mm	mm	mm	mm	mm	
3	1/8	24.6	10.4	2.4	14	11	18	19	D-FBT3-N2
6	1/8	27	10.4	4.8	14	14	19.6	19	D-FBT6-N2
6	1/4	29.8	15	4.8	19	14	22.4	22.4	D-FBT6-N4
8	1/8	29.9	10.4	6.3	16	16	22.4	19	D-FBT8-N2
8	1/4	30.6	15	6.3	19	16	23.1	22.4	D-FBT8-N4
10	1/4	33.5	15	7.9	19	19	25.9	22.4	D-FBT10-N4
12	3/8	36	15	9.5	22	22	25.9	22.4	D-FBT12-N6
12	1/2	38.8	19.8	9.5	27	22	28.7	28.2	D-FBT12-N8
16	1/2	39.5	19.8	12.7	27	25	29.7	28.5	D-FBT16-N8

TUBE OD - T	P	A	B	E	F	G	H	Hx	PART NO.
inch	NPT (F)	mm	mm	mm	mm	mm	mm	mm	
1/8	1/8	24.6	10.4	2.4	14	11	18	19	2D-FBTN
1/4	1/8	26.9	10.4	4.8	14	14	19.6	19	4-2D-FBTN
1/4	1/4	29.7	15	4.8	19	14	22.4	22.4	4D-FBTN
3/8	1/4	31.2	15	7.1	19	17	23.9	22.4	6-4D-FBTN
3/8	3/8	33.3	15	7.1	22	17	25.9	22.4	6D-FBTN
1/2	3/8	36	15	10.4	22	22	25.9	22.4	8-6D-FBTN
1/2	1/2	38.9	19.8	10.4	27	22	28.7	28.5	8D-FBTN
3/4	3/4	44.7	20.6	15.8	35	29	34.6	31.8	12D-FBTN
1	3/4	49	20.6	22.3	35	38	36.8	31.8	16-12D-FBTN
1	1	53.6	25.4	22.3	41	38	41.4	38.1	16D-FBTN

NOTE:
THE PART NUMBERS GIVEN HERE ARE FOR TAPER FEMALE BRANCH TEE. CORRESPONDING PART NUMBERS FOR TAPER FEMALE RUN TEE CAN BE OBTAINED BY SUBSTITUTING 'FRT' FOR 'FBT'.

S.D.INDUSTRIES.

An ISO 9001 : 2000 Company

Hydraulics, Pneumatics, Instrumentation Fittings, Manifolds & Valves

2/10, Singh Industrial Estate, Ram Mandir Road, Goregaon (W), Mumbai-400 104, India

◆ Phone: +91 22 28791745 / 55 / 56 ◆ Fax: +91 22 28752130

◆ Email: sdind@vsnl.com ◆ www.sdindustries.com

"We Deliver Confidence Through Quality Products."