

**FEMALE CONNECTOR
STUD END THREAD: NPT FEMALE**

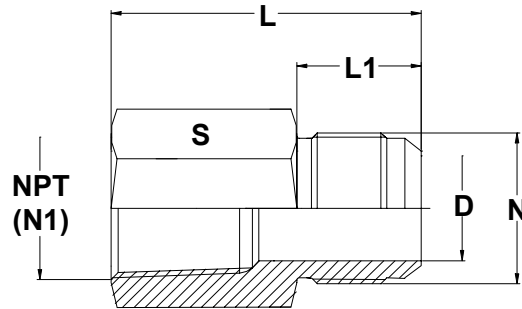

TUBE OD		UN / UNF N	THREAD NPT/NPTF N1	S mm	L mm	L1 mm	D mm	PART NO.
mm	inch							
6	1/4	7/16 -20	1/8 -27	14	30.2	14	4.4	4-2F-FCN
6	1/4	7/16 -20	1/4 -18	19	35.3	14	4.4	4F-FCN
8	5/16	1/2 -20	1/8 -27	14	29.7	14	6	5-2F-FCN
8	5/16	1/2 -20	1/4 -18	19	35.3	14	6	5-4F-FCN
10	3/8	9/16 -18	1/4 -18	19	35.8	14.1	7.5	6-4F-FCN
10	3/8	9/16 -18	3/8 -18	22	37.3	14.1	7.5	6F-FCN
12	1/2	3/4 -16	3/8 -18	22	39.6	16.7	9.9	8-6F-FCN
12	1/2	3/4 -16	1/2 -14	30	45.5	16.7	9.9	8F-FCN
14/15/16	5/8	7/8 -14	1/2 -14	30	48	19.3	12.3	10-8F-FCN
18/20	3/4	1 1/16 -12	1/2 -14	30	48.5	21.9	15.5	12-8F-FCN
18/20	3/4	1 1/16 -12	3/4 -14	36	52.3	21.9	15.5	12F-FCN
25	1	1 5/16 -12	1 -11.5	41	59.7	23.1	21.5	16F-FCN
28/30/32	1 1/4	1 5/8 -12	1 1/4 -11.5	50	63	24.3	27.5	20F-FCN
35/38	1 1/2	1 7/8 -12	1 1/2 -11.5	60	66.8	27.5	33	24F-FCN

S.D.INDUSTRIES.

An ISO 9001 : 2000 Company

Hydraulics, Pneumatics, Instrumentation Fittings, Manifolds & Valves

2/10, Singh Industrial Estate, Ram Mandir Road, Goregaon (W), Mumbai-400 104, India

◆ Phone: +91 22 28724724, +91 22 28738511 ◆ Fax: +91 22 28752130

◆ Email: sdind@vsnl.com ◆ www.sdinds.com

"We Deliver Confidence Through Quality Products."

