

**45 DEG. MALE ELBOW
STUD END THREAD: NPT**

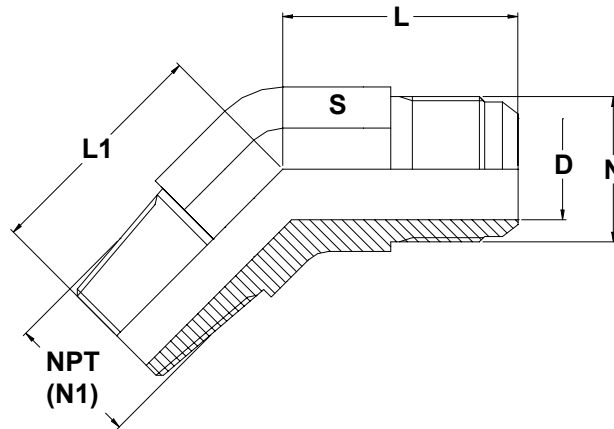

		UN / UNF	NPT/NPTF	S				PART NO.
mm	inch	N	N1	mm	mm	mm	mm	
6	1/4	7/16 -20	1/8 -27	11	18.3	16.3	4.4	4-2F-AMEN
6	1/4	7/16 -20	1/4 -18	14	20.8	21.8	4.4	4F-AMEN
8	5/16	1/2 -20	1/8 -27	13	19.6	16.3	6	5-2F-AMEN
8	5/16	1/2 -20	1/4 -18	14	20.8	21.8	6	5-4F-AMEN
10	3/8	9/16 -18	1/8 -27	14	21.1	21.8	7.5	6-2F-AMEN
10	3/8	9/16 -18	1/4 -18	14	21	17	7.5	6-4F-AMEN
10	3/8	9/16 -18	3/8 -18	19	22.1	24.1	7.5	6F-AMEN
10	3/8	9/16 -18	1/2 -14	22	22.4	29.7	7.5	6-8F-AMEN
12	1/2	3/4 -16	1/4 -18	19	25	24	9.9	8-4F-AMEN
12	1/2	3/4 -16	3/8 -18	19	24.9	24.1	9.9	8-6F-AMEN
12	1/2	3/4 -16	1/2 -14	22	24.9	29.7	9.9	8F-AMEN
12	1/2	3/4 -16	3/4 -14	27	26.5	30.5	9.9	8-12F-AMEN
14/15/16	5/8	7/8 -14	3/8 -18	22	28	25	12.3	10-6F-AMEN
14/15/16	5/8	7/8 -14	1/2 -14	22	28.2	29.7	12.3	10-8F-AMEN
14/15/16	5/8	7/8 -14	3/4 -14	27	29.5	30.5	12.3	10-12F-AMEN
18/20	3/4	1 1/16 -12	1/2 -14	27	32.5	30.5	15.5	12-8F-AMEN
18/20	3/4	1 1/16 -12	3/4 -14	27	32.5	33	15.5	12F-AMEN
18/20	3/4	1 1/16 -12	1 -11.5	33	36	32.5	15.5	12-16F-AMEN
25	1	1 5/16 -12	3/4 -14	33	37.5	37.6	21.5	16-12F-AMEN
25	1	1 5/16 -12	1 -11.5	33	37.3	37.6	21.5	16F-AMEN
28/30/32	1 1/4	1 5/8 -12	1 1/4 -11.5	41	40.4	42.4	27.5	20F-AMEN
35/38	1 1/2	1 7/8 -12	1 1/2 -11.5	48	45.2	45	33	24F-AMEN

S.D.INDUSTRIES.

An ISO 9001 : 2000 Company

Hydraulics, Pneumatics, Instrumentation Fittings, Manifolds & Valves

2/10, Singh Industrial Estate, Ram Mandir Road, Goregaon (W), Mumbai-400 104, India

◆ Phone: +91 22 28724724, +91 22 28738511 ◆ Fax: +91 22 28752130

◆ Email: sdind@vsnl.com ◆ www.sdinds.com

**45 DEG MALE ELBOW
TUD END THREAD: BSPT**

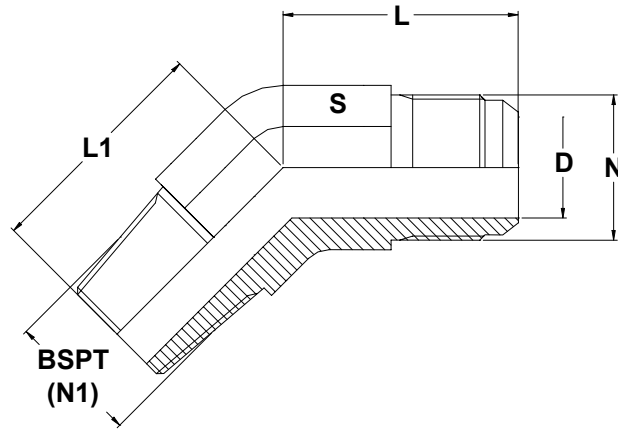

		THREAD UN / UNF	THREAD BSPT	S				PART NO.
mm	inch	N	N1	mm	mm	mm	mm	
6	1/4	7/16 -20	1/8 -28	11	18.3	16.3	4.4	4-2F-AMER
6	1/4	7/16 -20	1/4 -19	14	20.8	21.8	4.4	4F-AMER
8	5/16	1/2 -20	1/8 -28	13	19.6	16.8	6	5-2F-AMER
8	5/16	1/2 -20	1/4 -19	14	20.8	21.8	6	5-4F-AMER
10	3/8	9/16 -18	1/4 -19	14	21.1	21.8	7.5	6-4F-AMER
10	3/8	9/16 -18	3/8 -19	19	22.1	24.1	7.5	6F-AMER
10	3/8	9/16 -18	1/2 -14	22	22.4	29.7	7.5	6-8F-AMER
12	1/2	3/4 -16	3/8 -19	19	24.9	24.1	9.9	8-6F-AMER
12	1/2	3/4 -16	1/2 -14	22	25.2	29.7	9.9	8F-AMER
14/15/16	5/8	7/8 -14	1/2 -14	22	28.2	29.7	12.3	10-8F-AMER
18/20	3/4	1 1/16 -12	3/4 -14	27	32.5	30.5	15.5	12F-AMER
25	1	1 5/16 -12	1 -11	33	37.3	37.6	21.5	16F-AMER
28/30/32	1 1/4	1 5/8 -12	1 1/4 -11	41	40.4	42.4	27.5	20F-AMER
35/38	1 1/2	1 7/8 -12	1 1/2 -11	48	45.2	45	33	24F-AMER

S.D.INDUSTRIES.

An ISO 9001 : 2000 Company

Hydraulics, Pneumatics, Instrumentation Fittings, Manifolds & Valves

2/10, Singh Industrial Estate, Ram Mandir Road, Goregaon (W), Mumbai-400 104, India

◆ Phone: +91 22 28724724, +91 22 28738511 ◆ Fax: +91 22 28752130

◆ Email: sdind@vsnl.com ◆ www.sdinds.com



**45 DEG MALE ELBOW
TUD END THREAD: BSP**

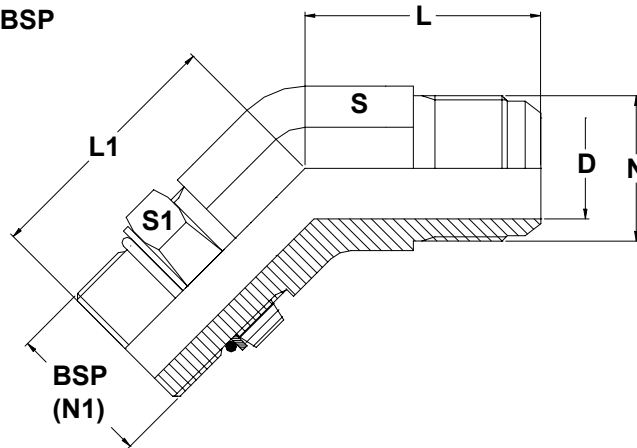

TUBE OD		THREAD UN / UNF	THREAD BSPT	S	L	L1	S1	D	PART NO.
mm	inch	N	N1	mm	mm	mm	mm	mm	
6	1/4	7/16 -20	1/8 -28	11	18.3	26.5	14	4.4	4-2F-AMEG
6	1/4	7/16 -20	1/4 -19	14	20.8	29	19	4.4	4F-AMEG
8	5/16	1/2 -20	1/8 -28	13	19.6	26.5	14	6	5-2F-AMEG
8	5/16	1/2 -20	1/4 -19	14	20.8	29	19	6	5-4F-AMEG
10	3/8	9/16 -18	1/4 -19	14	21.1	29	19	7.5	6-4F-AMEG
12	1/2	3/4 -16	3/8 -19	19	24.9	33	22	9.9	8-6F-AMEG
12	1/2	3/4 -16	1/2 -14	22	25.2	38.5	27	9.9	8F-AMEG
14/15/16	5/8	7/8 -14	1/2 -14	22	28.2	38.6	27	12.3	10-8F-AMEG
14/15/16	5/8	7/8 -14	3/4 -14	27	29.5	44	36	12.3	10-12F-AMEG
18/20	3/4	1 1/16 -12	3/4 -14	27	32.5	44	36	15.5	12F-AMEG
25	1	1 5/16 -12	1 -11	33	37.2	47	41	21.5	16F-AMEG
28/30/32	1 1/4	1 5/8 -12	1 1/4 -11	41	40.4	48	50	27.5	20F-AMEG

S.D.INDUSTRIES.

An ISO 9001 : 2000 Company

Hydraulics, Pneumatics, Instrumentation Fittings, Manifolds & Valves

2/10, Singh Industrial Estate, Ram Mandir Road, Goregaon (W), Mumbai-400 104, India

◆ Phone: +91 22 28724724, +91 22 28738511 ◆ Fax: +91 22 28752130

◆ Email: sdind@vsnl.com ◆ www.sdinds.com

"We Deliver Confidence Through Quality Products."

**45 DEG MALE ELBOW
TUD END THREAD: UNF**

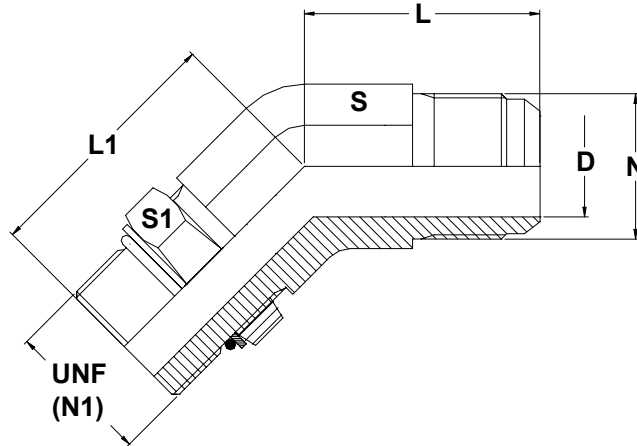

TUBE OD		THREAD UN / UNF	THREAD UN / UNF	S	L	L1	S1	D	PART NO.
mm	inch	N	N1	mm	mm	mm	mm	mm	
6	1/4	7/16 -20	7/16 -20	11	18.3	26.7	14	4.4	4-7F-AMEU
8	5/16	1/2 -20	1/2 -20	13	19.6	26.7	17	6	5-8F-AMEU
10	3/8	9/16 -18	9/16 -20	14	21.1	29	17	7.5	6-9F-AMEU
10	3/8	9/16 -18	3/4 -16	19	24.9	29.7	17	7.5	6-12F-AMEU
12	1/2	3/4 -16	3/4 -16	19	24.9	33	22	9.9	8-12F-AMEU
12	1/2	3/4 -16	7/8 -14	22	25.2	38.6	27	9.9	8-14F-AMEU
14/15/16	5/8	7/8 -14	3/4 -16	22	28.2	34.5	22	12.3	10-12F-AMEU
14/15/16	5/8	7/8 -14	7/8 -14	22	28.2	38.6	27	12.3	10-14F-AMEU
18/20	3/4	1 1/16 -12	7/8 -14	27	32.5	39.8	27	15.5	12-14F-AMEU
18/20	3/4	1 1/16 -12	1 1/16 -12	27	32.5	43.9	32	15.5	12-17F-AMEU
25	1	1 5/16 -12	1 5/16 -12	33	37.3	47.2	41	21.5	16-21F-AMEU
28/30/32	1 1/4	1 5/8 -12	1 5/8 -12	41	40.4	48.5	50	27.5	20-26F-AMEU
35/38	1 1/2	1 7/8 -12	1 7/8 -12	48	45.2	48.5	55	33	24-30F-AMEU

S.D.INDUSTRIES.

An ISO 9001 : 2000 Company

Hydraulics, Pneumatics, Instrumentation Fittings, Manifolds & Valves

2/10, Singh Industrial Estate, Ram Mandir Road, Goregaon (W), Mumbai-400 104, India

◆ Phone: +91 22 28724724, +91 22 28738511 ◆ Fax: +91 22 28752130

◆ Email: sdind@vsnl.com ◆ www.sdinds.com

"We Deliver Confidence Through Quality Products."