

BONNET ASSEMBLY

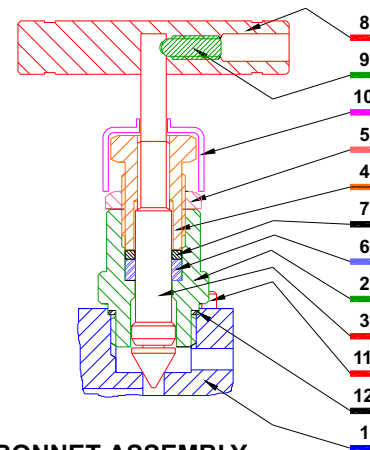

FEATURES :

- 2 VALVE MANIFOLD (H TYPE)
 - 2 valve manifolds are designed for direct mounting. Connecting from process side Flange connection and Instrument side Flange connection on suitable for DP transmitter. Connecting system impulse lines and transmitters, having simple two valves configuration which allows for easy block or Isolate, Bleed or Vent valve calibration of a static pressure transmitter or gauge.
 - Bleed/vent connection with s.s. plug will be provided on request.
 - Approximate weight : xxx Kg (xxx Lbs.).
 - Heat code traceability
- BONNET ASSEMBLY
 - Screwed bonnet design.
 - Bonnet-back seated blow out proof.
 - Spindle - Ground and thread rolled.
 - Spindle tip-Non rotating tip shut off type
 - stellited, Regulating-stellited and soft seated.
 - Bonnet pusher - silver plated for anti galling freezing for increased stem cycle life.
 - Dust cap protects stem threads from externals contamination.
 - Leak tight seal with low operating torque.

NO	DESCRIPTION	QTY	MATERIAL
1	BODY	1	SS 316
2	BONNET	1	SS 316
3	STEM	1	SS 316
4	BONNET PUSHER	1	SS 316
5	LOCK NUT	1	SS 316
6	PACKING	1	TEFLON
7	WASHER	1	SS 316
8	HANDLE	1	SS 304
9	GRUB SCREW	1	SS
10	DUST CAP	1	PLASTIC
11	LOCKING PIN	1	SS 304
12	BONNET SEAL	1	TEFLON

- TECHNICAL SPECIFICATIONS

- Size : 1/4", 1/2"
- End connection : NPT,BSPT,Socket weld.
- Working Pressure : 6000 Psi (413 Bar)
- Temperature Rating : PTFE 450 Deg. F (232 Deg.C) Grafoil 700 Deg. F (371 Deg. C)
- Material of construction : SS 316, SS 304, Monel,C.S.
- Optional Sour Gas service valves are available confirming to NACE Std. MR - 01 - 75
- Stem packing : PTFE, Grafoil.
- Orifice : Dia. 4.0
- All valves are 100% Factory tested prior to shipment.

- APPLICATION

- Refineries, liquid petroleum gas processing plant, petro-chemical plants, systems difficult to shur off due to solid contents dust, rust, dirt etc.

- MANIFOLD SELECTION INFORMATION DATA

- Pressure & temperature ratings are selected from ANSI B 16.34 for standard class 2500

- TESTING

- Pneumatic Seat test is performed at 1/4 of working pressure.
- Hydrostatic shell test is performed at 1.5 times the working pressure.
- Optional test are available upon request.

- LUBRICATION

- Dye molly sulphide

DRN. BY	Mr.SATYAWAN	DRAWING NO :	CH - 2VMH - 00 - CL	REV :	00
APPRD. BY	Mr.TEJINDER	TITLE :	2 VALVE MANIFOLD (H TYPE) (MODEL : 2VMH) (FLANGE TO FLANGE CONNECTION)		
MATERIAL	AS GIVEN				
SCALE	NTS			S.D.INDUSTRIES	
		THIRD ANGLE PROJ		Tel : 91-22-28724724 / 28738511 Fax : 91-22-28752130 Web : www.sdindustries.com Email : sdind@vsnl.com	